



RFWORLD

Documents Version: 1.80

Document No. 2008-0068-E

Copyright is reserved by Rping Group Limited (2008-2011)

RF Module

(WM24TR_S_S)

USER GUIDE

Shenzhen,China: RF WORLD (RPinG Group)

15F,Nanshang Block,Zhongyin Bldg.,Caitian Rd.,Shenzhen 518026,China

Tel:86 755 82469767 82469790

Fax:86 755 82469915

Email: sales@mcurf.com www.mcurf.com

Index

Documents Version: 1.80 1

1 summary: 3

2.1 DEMO 3D graphic: 4

2.2 WM24TR_S_S 3D graphic: 5

 R2, PIN2 , PIN3 Selected (Input Pins) 6

 D/C PIN (Input Pin) 6

 SLEEP PIN(Input Pin)..... 6

 UART Interface and Power interface (J1) 7

 LED : 7

3 Command Setting: 8

 3.1 Format of system parameter : 8

 A Transmit Power control : 8

 B Channel Select : 8

 C Save Parameter to EEPROM of base band chip : 8

 D Output Parameter through UART while rebooting 8

 E Air Baud Rate 9

 System Return : 9

 3.2 Switch Channel quickly : 9

 A Channel Number : 9

 CHK Checksum : 9

 SYSTEM Return : 10

 3.3 How to setting the parameter : 10

4.0 RF Module: 11

 4.1WM2500S : 11

 4.2 WM2500 : 12

5.0 Package Base Band Chip: 13

6.0 System Block: 13

7.0SCH..... 13

1 summary:

2.4G UART Module is designed for wireless communication with serial interface.

Distant depend on the module size and air data Rate. Please see Table: 1.1 for more details.

Distant Table: 1.1

NO.	Air Data Rate	Module (P/N)	Distant (Meter)
1	125K	WM2500S	10-15
2	10K	WM2500S	20-30
3	1.2K	WM2500S	30-50
4	125K	WM2500	20-30
5	10K	WM2500	50-70
6	1.2K	WM2500	80-120

UART Data Rate can be chose.(57600 , 38400 , 19200 , 9600 , 4800 , 2400)

Work Voltage: 2.7V-3.6V

Power consumption: (Working mode: 18-23MA , Power Down < 10UA)

Working mode: Transparent transmit and receive (Half Duplex). The data maybe miss if both side send the data in the same time.

The Max package length is 64 BYTE (the buffer can be tailor according to requirement)

Customer can use the WM24TR_S_S UART wireless modules or use demo board to estimate the performance of modules. Customer can only order the base band chip and RF module and then assemble them to customer board in order to reduce the size/

2.1 DEMO 3D graphic :

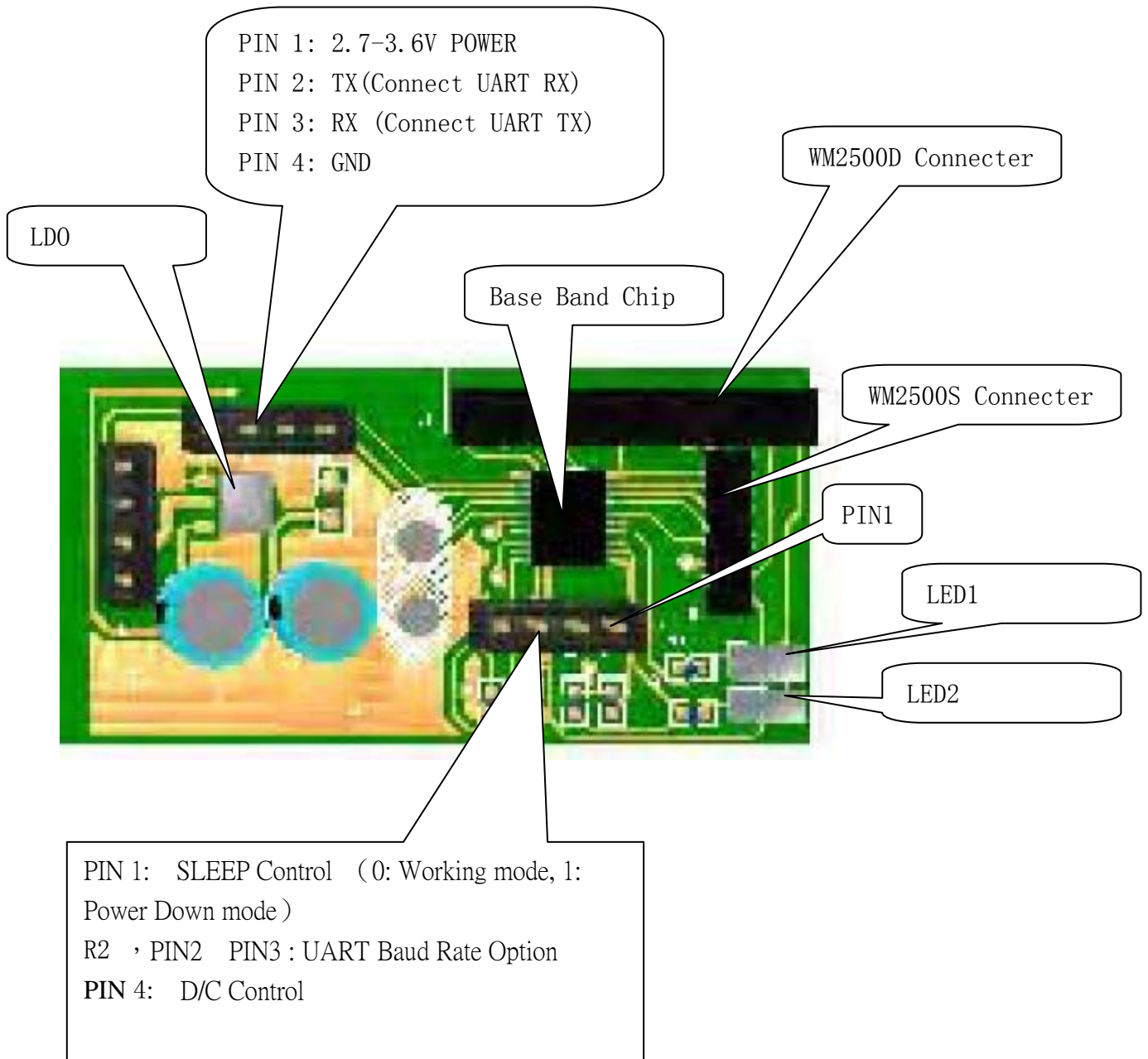

2.2 WM24TR_S_S 3D graphic :

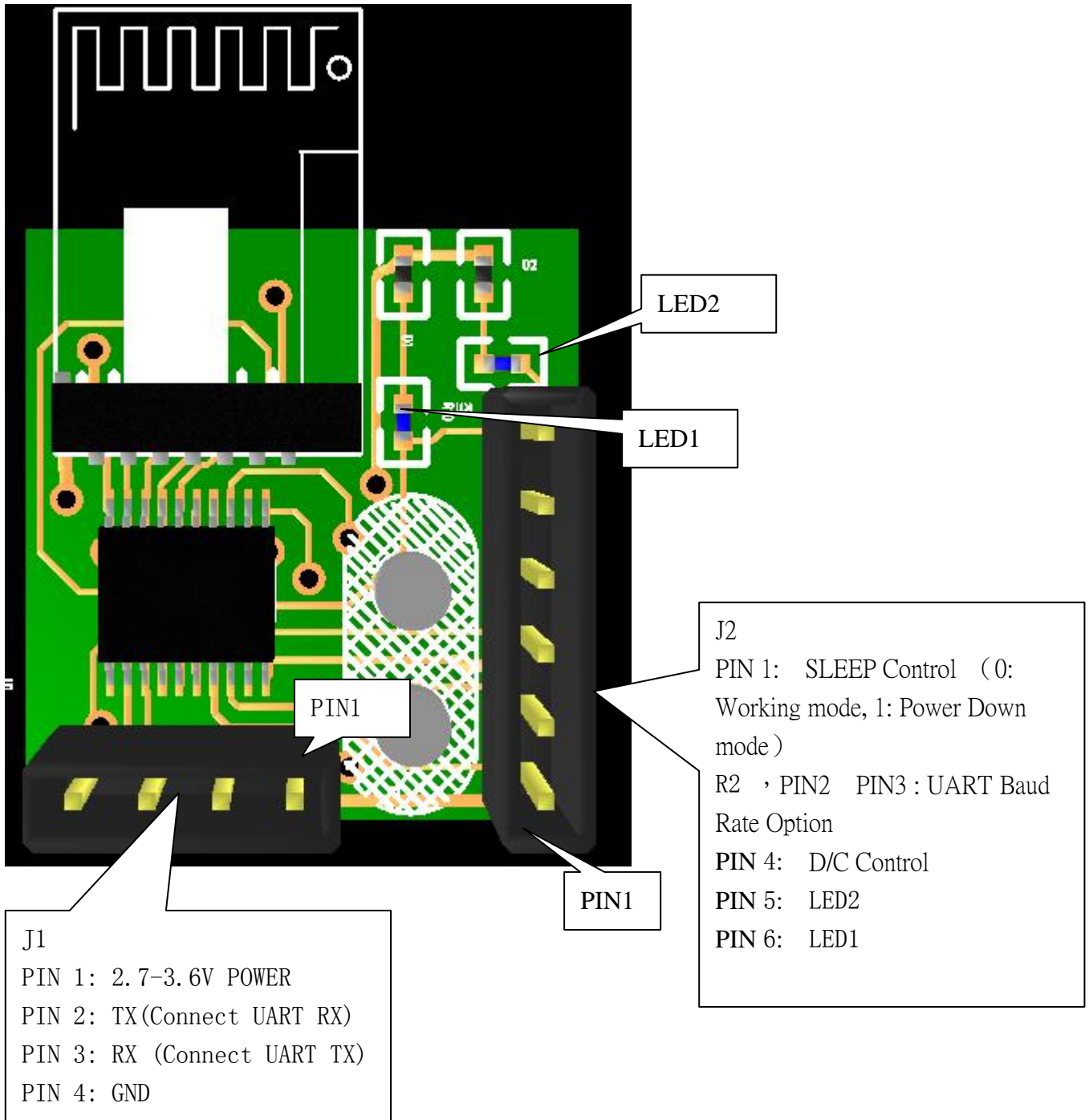

SIZE: 21MM * 30MM

R2, PIN2 , PIN3 Selected (Input Pins)

No	R2	PIN2 , PIN3	UART Baud rate
1	1	11	57600
2	1	10	38400
3	1	01	19200
4	1	00	9600
5	0	X1	4800
6	0	X0	2400

0: Connect to GND

1: Float or add 10k pull to VDD.

X: Not care

The UART Baud Rate can be tailored by customer.

D/C PIN (Input Pin)

The D/C PIN decides that the data should be handled as data or command.

No	D/C PIN	STATUS
0	1	Data
1	0	Command

NOTE:

The system will start to transfer or handle as command after getting a package.

Once receiving the first byte, the system take the data in buffer as a package while there is no data to be receive in 5 MS.

In order make sure the module work well, the interval time between 2 closed bytes must less 3MS. It can be easy to see before the following graphic.

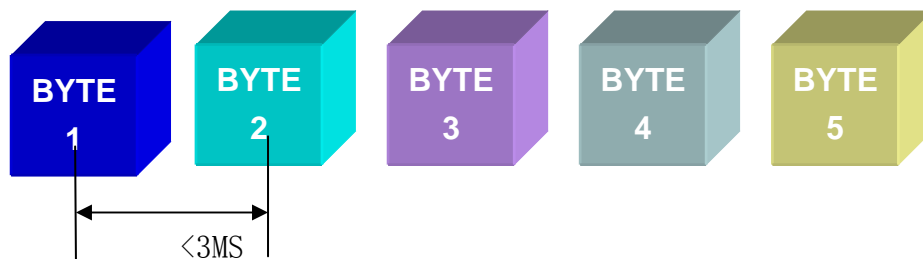

SLEEP PIN(Input Pin)

The SLEEP PIN decides the work mode.

No	SLEPPIN	WORK MODE
0	0	Working mode

1	1	Power Down Mode
---	---	-----------------

UART Interface and Power interface (J1)

No	PINS	Description
1	VDD	2.7-3.6V
2	TX	Connect UART RX (Output Pin TTL)
3	RX	Connect UART TX (Input Pin TTL)
4	GND	Grand

In order to make sure the transmitting distant, please reduce the noise of power supply.

LED :

LED 1 Communication indictor:

The LED is on when UART getting a package. The LED is off after that package is sent.

LED 2 is power indicator and flash once a second.

3 Command Setting :

3.1 Format of system parameter :

It consist of A,B,C,D,E , Chk and can be shown in below illustration.

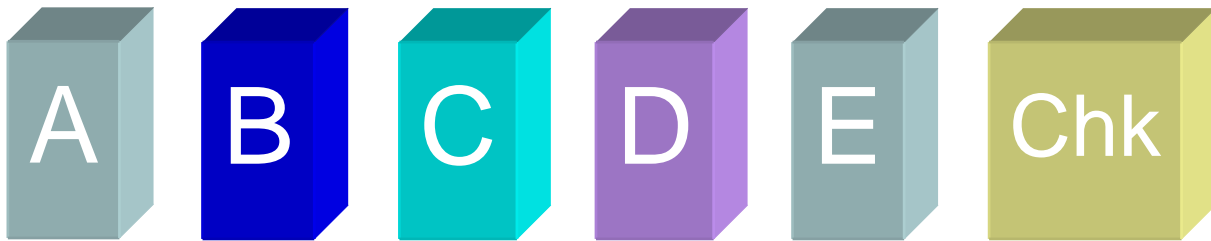

A Transmit Power control : Length (1 BYTE)

Range: From 0x00– 0x0F (16 levels) (HEX Format)

0 is mean that the power is maximize and F is Min.

B Channel Select : Length (1 BYTE)

Range: From 0x00– 0xFF (255 channels) (HEX Format)

Only in the same channel, it can be used to exchange data among the modules.
The different channel can work in the same time.

C Save Parameter to EEPROM of base band chip : Length (1 BYTE)

Range: 0x00 or 0x01 (HEX Format)

0 denote that the Parameter will be stored into EEPROM.

1 denote that the parameter is only used in this time and will be lost when reboot again.

Note: The parameter can be stored over 5000 times.

D Output Parameter through UART while rebooting Length (1 BYTE)

Range: 0x00 or 0x01 (HEX Format)

0 denote that the Parameter will be outputted after rebooting.

1 denote that the parameter will not be outputted after rebooting.

E Air Baud Rate Length (1 BYTE)

Num	Value	Description
1	0	125K
2	1	5K
3	2	1.2K
4	other	Reserve

System Return : Length (3 BYTE)

If the parameters had been received successfully, string of “SUC” will be outputted with UART, otherwise string of “ERR” will be outputted.

3.2 Switch Channel quickly :

It consist of A, Chk and shown as below.



A Channel Number : Length (1 BYTE)

Range: From 0x00– 0xFF (255 channels) (HEX Format)

Only in the same channel, it can be used to exchange data among the modules. The different channel can work in the same time.

CHK Checksum : Length (1 BYTE)

The same data with A.

SYSTEM Return : Length (1 BYTE)

If the channel had been changed successfully, Channel No (A, HEX Format). will be outputted with UART, otherwise nothing will be outputted.

3.3 How to setting the parameter :

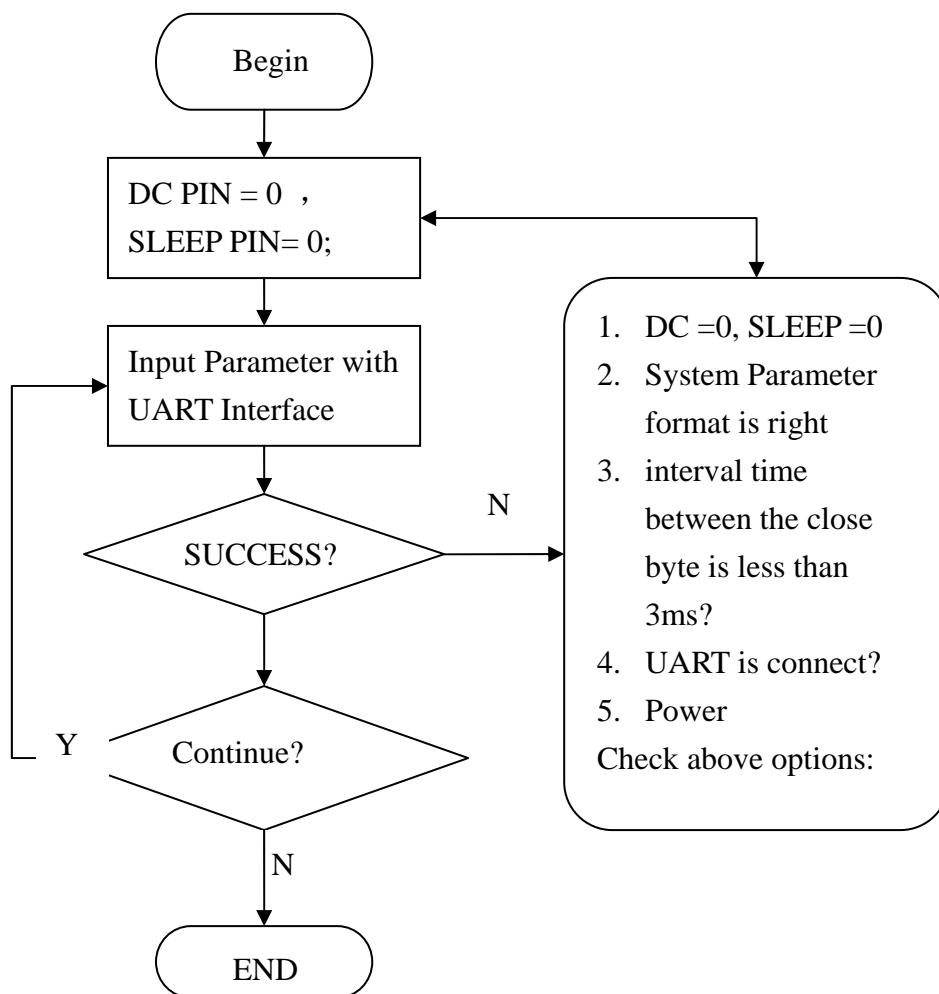

4.0 RF Module :

4.1WM2500S :

- WM2500S

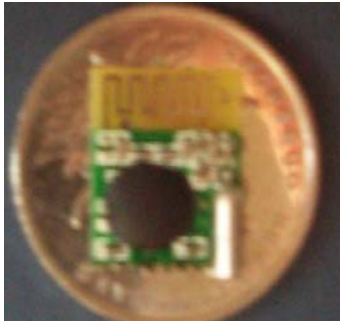

Pin	Symbol	Function
1	GND	Ground
2	VDD	supply voltage
3	DATA1	DATA 1
4	CLK	Clock in
5	DATA2	DATA 2
6	NC	NC
7	FUN1	FUNCTION 1
8	FUN2	FUNCTION 2

Parameter	Min	Max
VDD	2.4	3.6V
Operation temperature	-10	60
storage temperature	-40	85
size	11.6mm*15.7mm*3.5mm	

4.2 WM2500 :

- WM2500

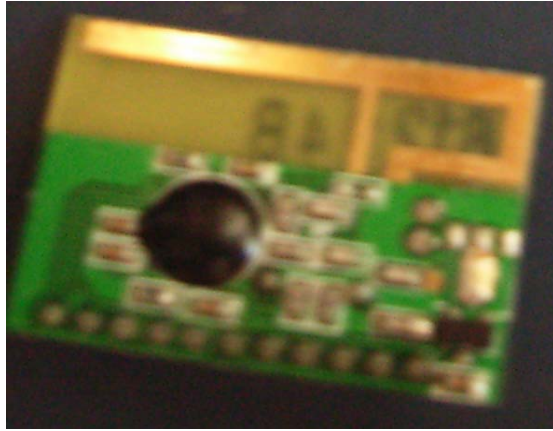

Pin	Symbol	Function
1	DATA2	DATA 2
2	SCLK	CLK INPUT
3	DATA1	DATA 1
4	FUN1	Function 1
5	GND	Ground
6	VDD	supply voltage
7	NC	
8	NC	
9	NC	
10	NC	
11	FUN2	Function 2

Parameter	Min	Max
VDD	2.4	5V
Operation temperature	-10	60
Storage temperature	-40	85
SIZE	27mmx20mmx5mm	

5.0 Package Base Band Chip :

TSSOP20

6.0 System Block :

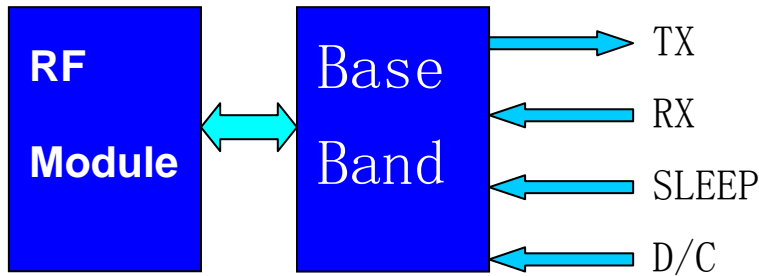

7.0SCH

